

# Water as Refrigerant: Sustainable Cooling

University of Toronto, MIE491 Capstone · Client: Enersion Inc. · Oct 2024 to Mar 2025 · Team of four

Design sections

Figure creation

## Capstone design of a water-refrigerant (R718) air-conditioning system for cleantech client Enersion.

A capstone for Toronto cleantech client Enersion Inc. designing a small-scale refrigeration system that uses water (R718, global-warming potential under 1) in place of high-GWP refrigerants, motivated by the Kigali Amendment phase-down of HFCs. The team reviewed vapour-compression, evaporative, absorption, and adsorption cycles, evaluated three candidate designs, and converged on a single-stage vapour-compression cycle with selected commercial components. My credited work spans the chosen-design and future-work sections, the functions-objectives-constraints discussion, and the creation of several figures.

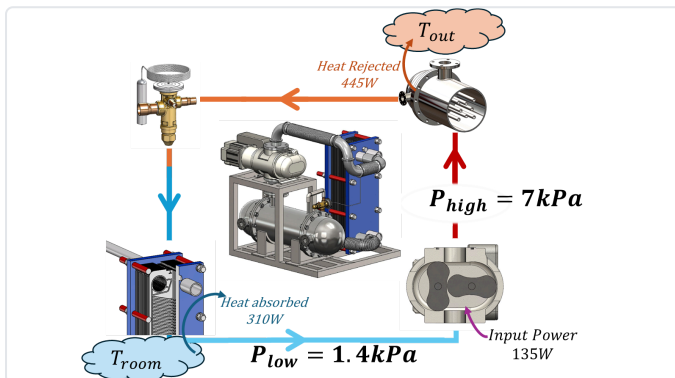

Final cycle energy-flow diagram (a figure I created): 310 W absorbed, 445 W rejected, 135 W input.

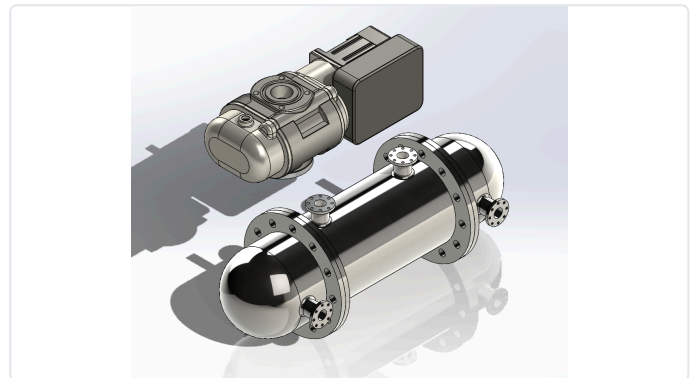

3D CAD of the final assembly: roots compressor and shell-and-tube condenser.

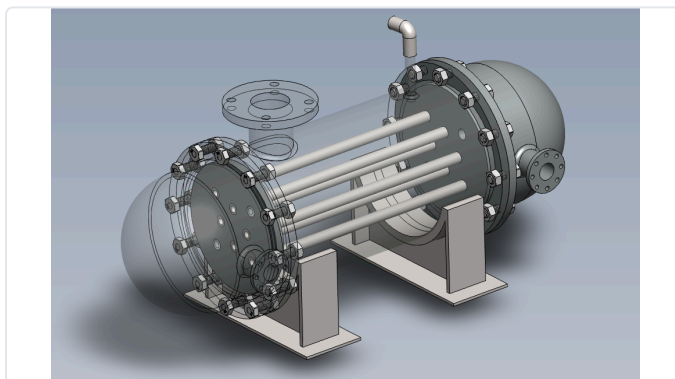

CAD of the stainless shell-and-tube condenser.

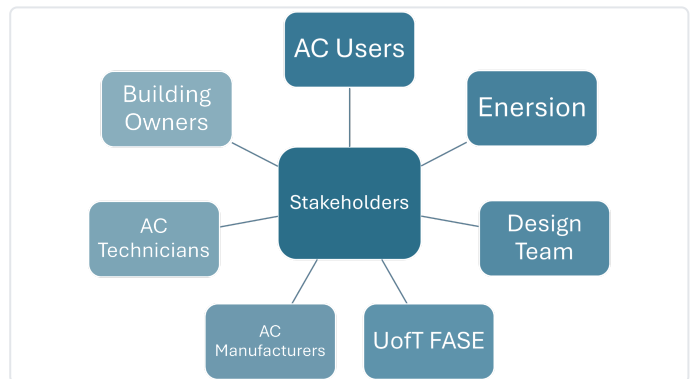

Stakeholder map across users, client, design team, and manufacturers.

## Cycle and component selection

Thermodynamic cycle calculations compared single-stage and two-stage configurations. The two-stage intercooler looked best in theory but became infeasible once real compressor power was included, so the team selected a single-stage cycle with an oil-free roots compressor, a stainless shell-and-tube condenser, a gasketed plate-heat-exchanger evaporator, and a modified thermal expansion valve.

## Results and honest limits

The final design reached a cooling capacity of 310 W with an actual coefficient of performance of 2.30 against a theoretical 9.45, at an estimated cost of about \$13,800 CAD and overall dimensions of 722 by 469 by 605 mm. No physical prototype was built. The report is candid that the theory-to-actual gap comes from the scarcity of oil-free, vacuum-capable, high-flow compressors for a water refrigerant.

## SELECTED REFERENCES

- Enersion Inc., Cooling Technology (adsorption chiller, water refrigerant), enersion.com.
- "Vapor Compression Cycle: water and other natural refrigerants," Clean Technologies (MDPI), May 2023.
- Kigali Amendment to the Montreal Protocol, UNEP, 2016 (HFC phase-down).